

# RESCUE PERFECTSPEED® ECM Ventilation Motor with User Interface for Speed Control High Efficiency

## APPLICATIONS:

Commercial Ventilation and other air moving applications



## FEATURES:

### User Interface:

- 0-10 VDC, remote or on-board potentiometer
- LED display indicates RPM and percent of demand
- Powered off any line voltage from 115V-277V no separate transformer required
- 300 RPM minimum speed
- Optional remote potentiometer (customer supplied) allows control from up to 50' away

### Motor:

- High Efficiency ECM Motor
- Open Air Over
- Efficiency: Up to 82%
- Frame: NEMA® 48
- Motor output is indicated via a 7 segment LED

## 1200 RPM

HP	RPM	Volts	Catalog Number	Amps	HZ	Rotation	Shell Length (A)	Shaft Length (D)	Shaft Dia.	Total Length (D)	Ship Wt.
1/2-1/3	300-1200	277	7630UI	3.2	50/60	CWLE	3.531	4.5	0.5	10.75	12
	300-1200	277	7631UI	3.2	50/60	CCWLE	3.531	4.5	0.5	10.75	12
1-3/4	300-1200	277	7650UI	6.0	50/60	CWLE	4.531	4.5	0.5	11.75	18
	300-1200	277	7651UI	6.0	50/60	CCWLE	4.531	4.5	0.5	11.75	18
1/2-1/3	300-1200	115/208-230	8630UI	6.2/4.2-3.8 & 6.6/4.0-3.8	60&50	CWLE	3.531	4.5	0.5	10.25	12
1/2-1/3	300-1200	115/208-230	8631UI	6.2/4.2-3.8 & 6.6/4.0-3.8	60&50	CCWLE	3.531	4.5	0.5	10.25	12
1-3/4	300-1200	115/208-230	8650UI	11.0/7.7-6.7 & 11.8/7.3-6.6	60&50	CWLE	4.531	4.5	0.5	11.75	18
1-3/4	300-1200	115/208-230	8651UI	11.0/7.7-6.7 & 11.8/7.3-6.6	60&50	CCWLE	4.531	4.5	0.5	11.75	18

## 1800 RPM

HP	RPM	Volts	Catalog Number	Amps	HZ	Rotation	Shell Length (A)	Shaft Length (D)	Shaft Dia.	Total Length (D)	Ship Wt.
1-3/4	300-1800	115/208-230	8450UI	12.4/8.1-7.2 & 11.8/7.4-6.4	60&50	CWLE	4.531	4.5	0.5	11.75	18
	300-1800	115/208-230	8451UI	12.4/8.1-7.2 & 11.8/7.4-6.4	60&50	CCWLE	4.531	4.5	0.5	11.75	18
1/2-1/3	300-1800	115/230	8431UI	5.6/3.2	50/60	CCWLE	3.531	4.5	0.5	10.25	12
	300-1800	115/230	8430UI	5.6/3.2	50/60	CWLE	3.531	4.5	0.5	10.25	12



### Flexible User Interface:

- User Interface can be mounted directly to motor or remote mounted within unit enclosure
- Vertical or horizontal mounting to a standard receptacle box using mounting holes provided
- Adjust motor speed by using the on-board or a user-supplied external potentiometer

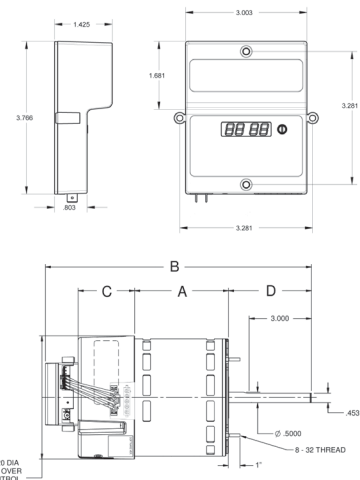

† All marks shown within this document are properties of their respective owners.

